

401

*МЕХАНИЗМ ОТКРЫВАНИЯ  
ГОРЛОВЫХ КОЛЕЦ  
МТ-401-001 (191-D-5149)*

Механизм открывания горловых колец  
МТ-401-001

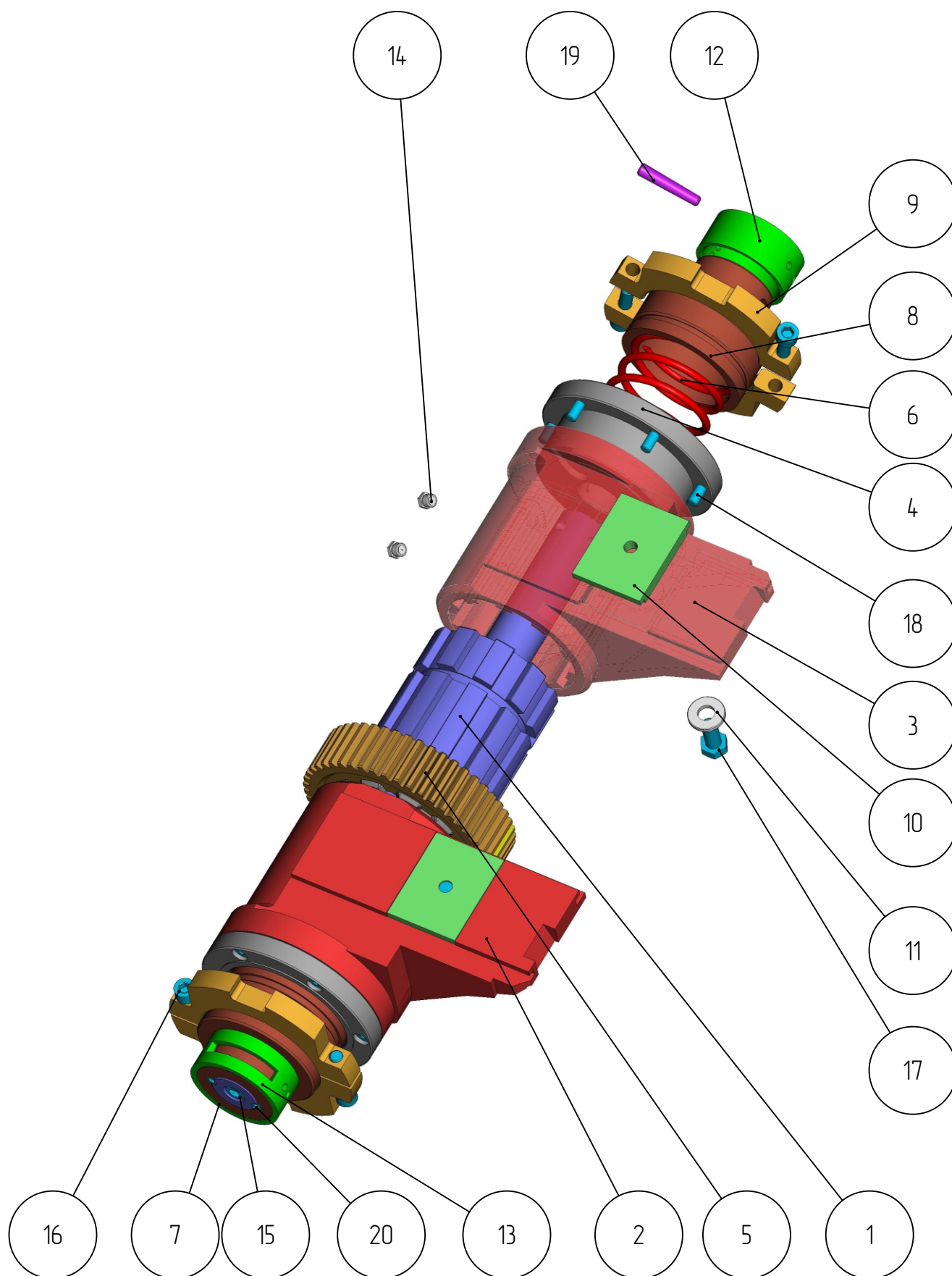

Механизм открывания горловых колец  
МТ-401-001

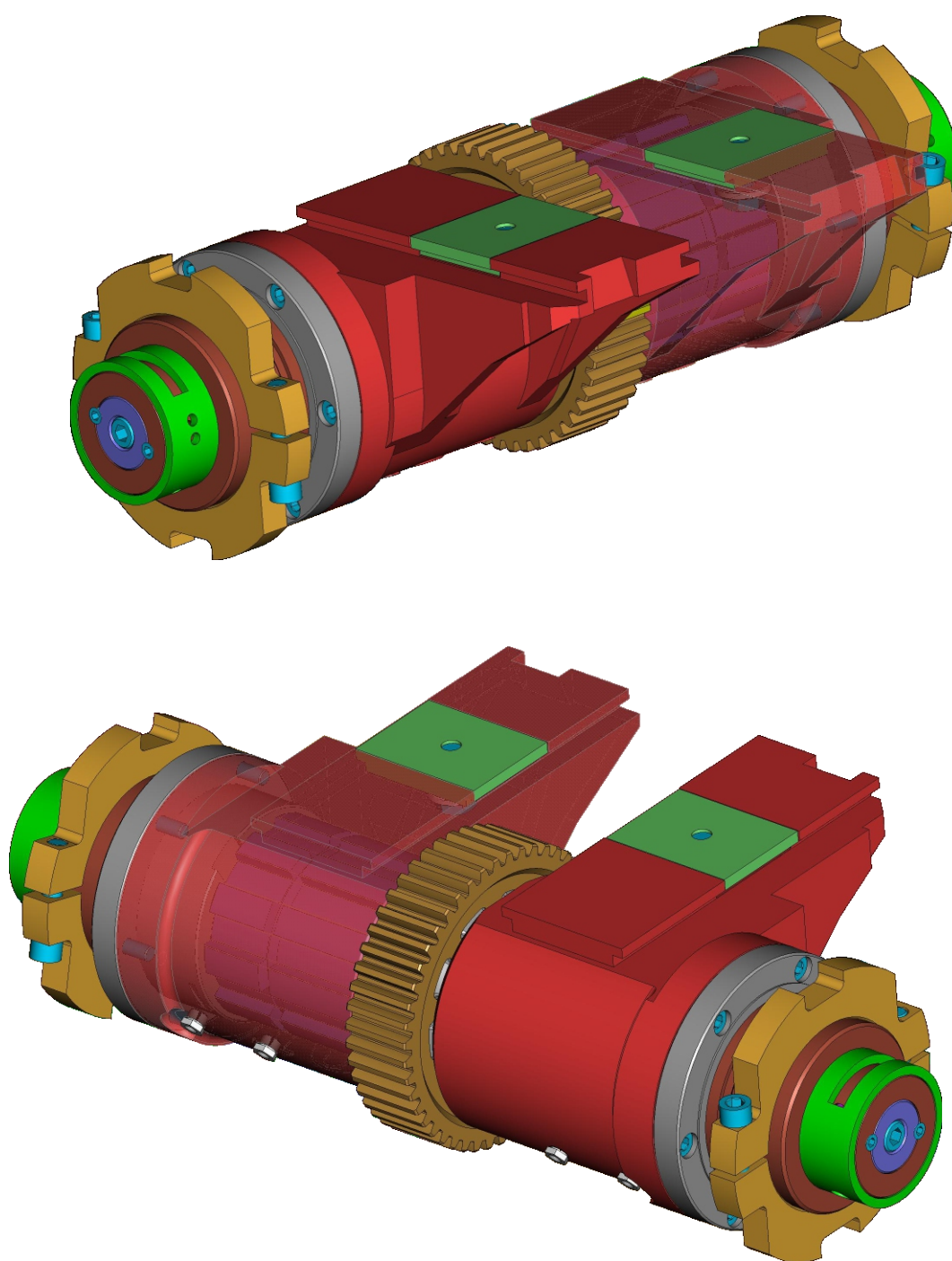

Механизм открывания горловых колец  
МТ-401-001

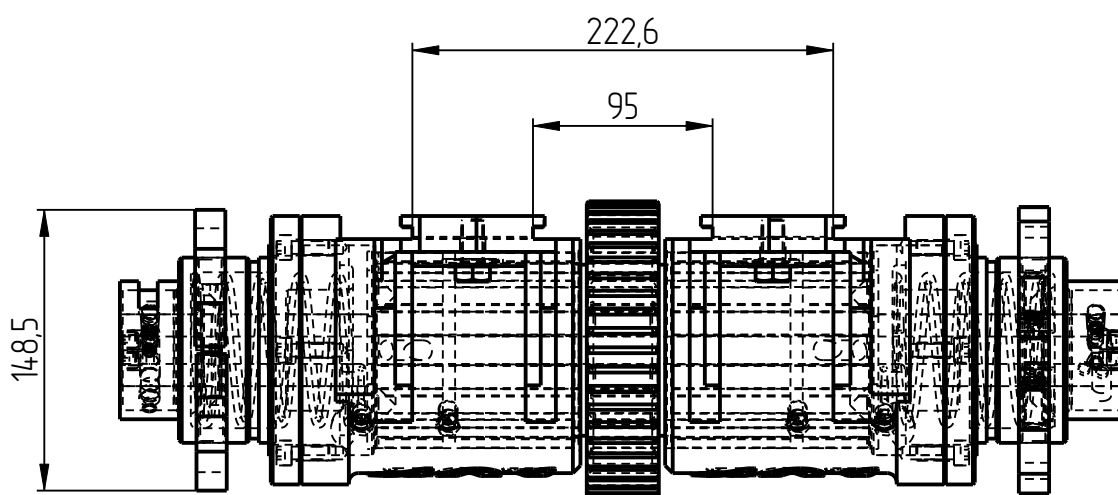
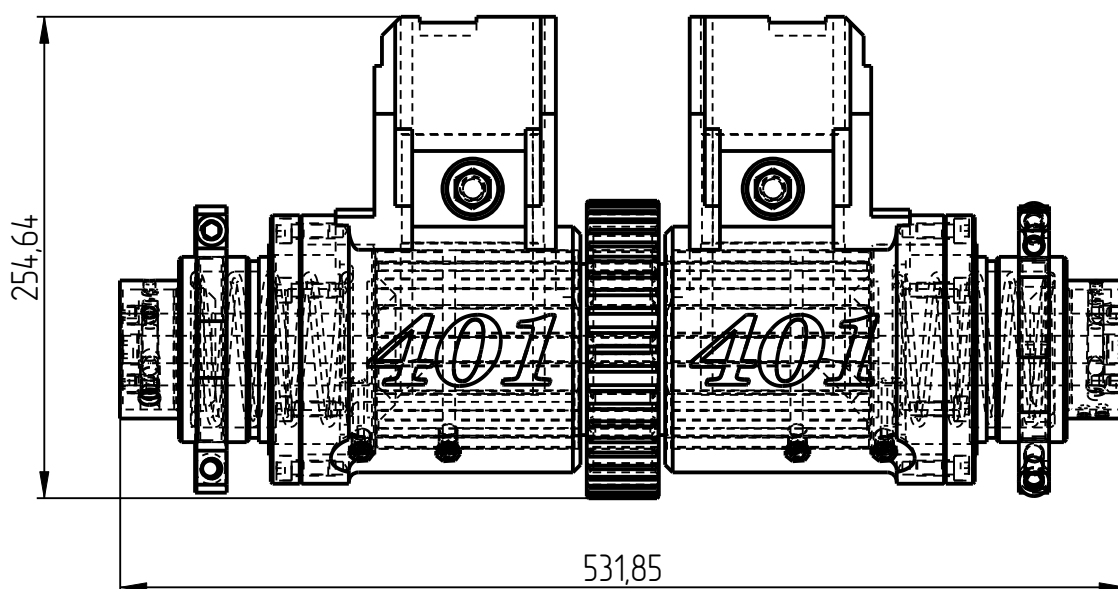

## Механизм открывания горловых колец МТ-401-001

### Спецификация

№ поз.	Шифр	Наименование	Кол-во
<b>Детали</b>			
1	МТ-401-001-001	Вал шлицевой	1
2	МТ-401-001-002	Корпус подвижный левый	1
3	МТ-401-001-002-01	Корпус подвижный правый	1
4	МТ-401-001-003	Фланец	2
5	МТ-401-001-004	Зубчатое колесо	1
6	МТ-401-001-005	Пружина	2
7	МТ-401-001-006	Корпус неподвижный левый	1
8	МТ-401-001-007	Корпус неподвижный правый	1
9	МТ-401-001-008-01	Гайка разрезная	1
10	МТ-401-001-009	Прижим	2
11	МТ-401-001-010	Шайба	2
12	МТ-401-001-011	Кольцо	1
13	МТ-401-001-012	Кольцо	1
<b>Стандартные изделия</b>			
14	Пресс маслёнка М10х1 DIN_3405		4
15	Пробка коническая МК16х1,5 DIN 906		2
16	Винт М10х50 DIN 912		4
17	Болт М12х25 DIN 933		2
18	Винт М8х20 DIN 912		12
19	Штифт 8х50 DIN 1		2
20	Винт М10х10 DIN 913		4

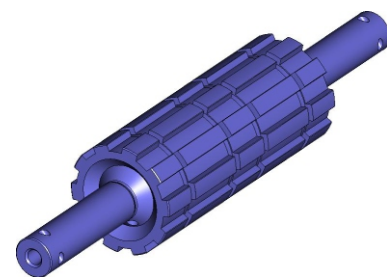
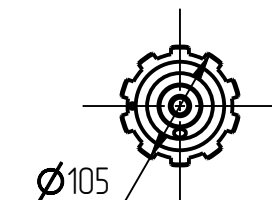
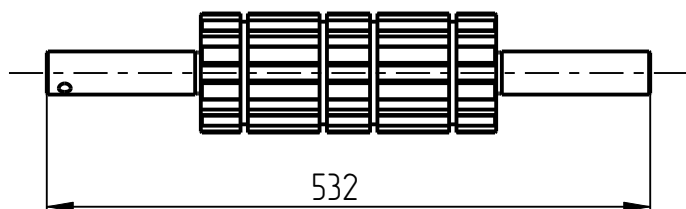

1. Вал шлицевой  
MT-401-001-001

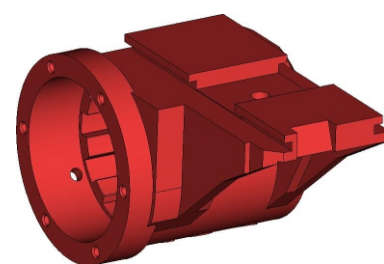
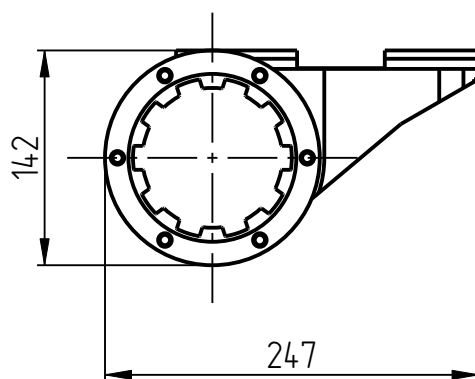
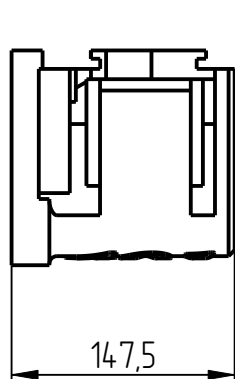

2. Корпус подвижный  
MT-401-001-002

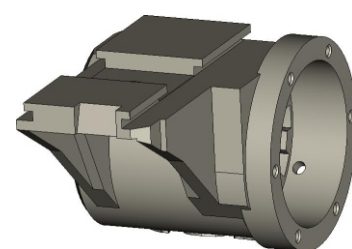
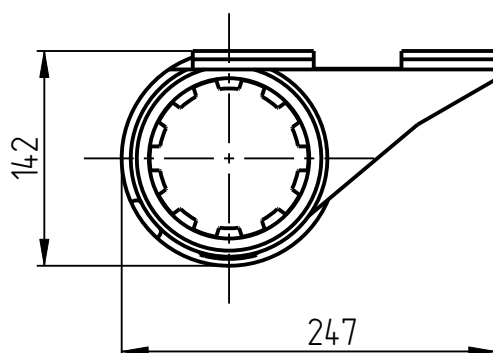
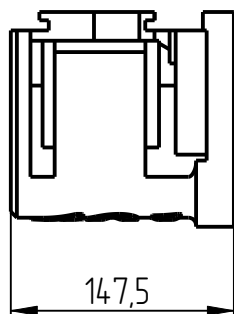

3. Корпус подвижный  
MT-401-001-002-01

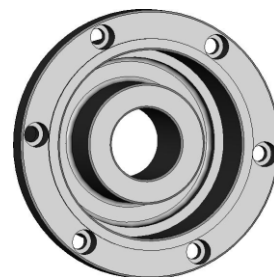
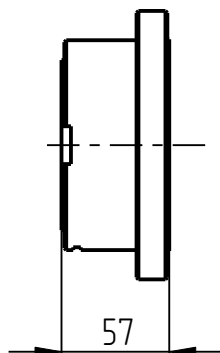
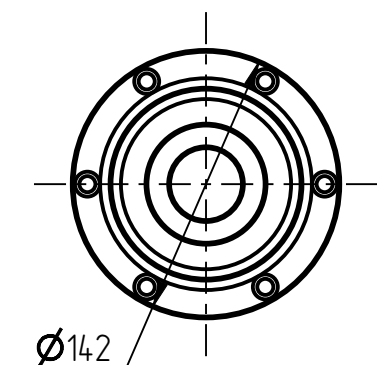

4. Фланец  
МТ-401-001-003

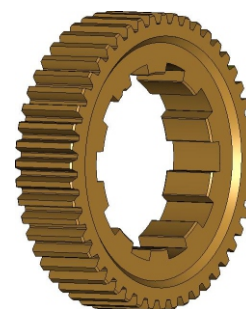
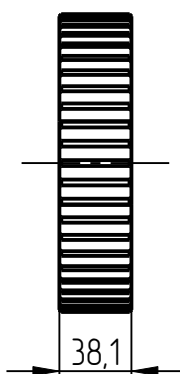
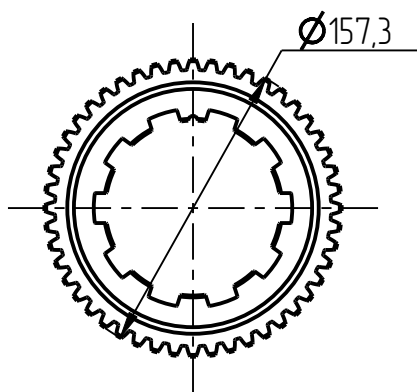

5. Зубчатое колесо  
МТ-401-001-004

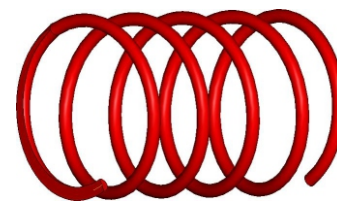
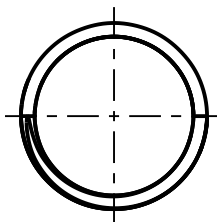
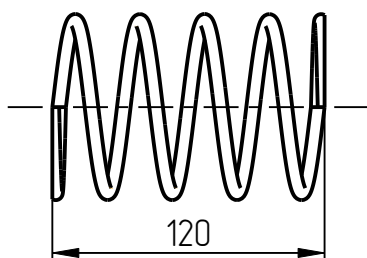

6. Пружина  
МТ-401-001-005

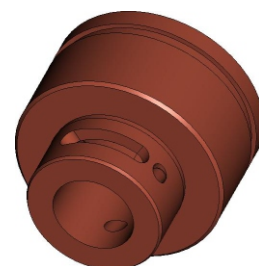
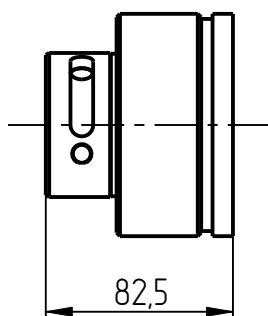
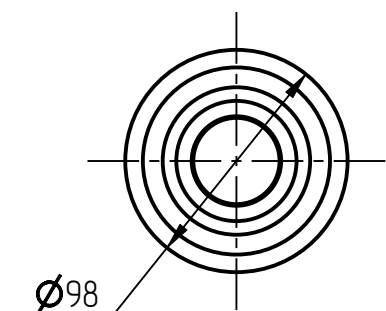

7. Корпус неподвижный  
левый  
MT-401-001-006

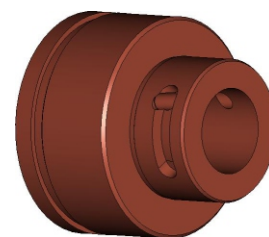
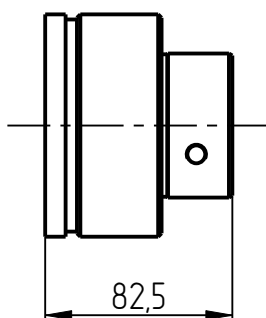
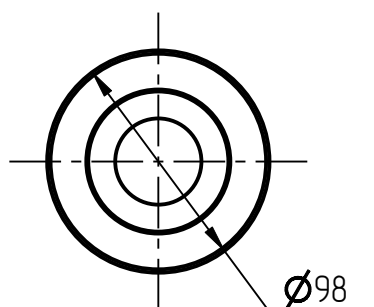

8. Корпус неподвижный  
правый  
MT-401-001-007

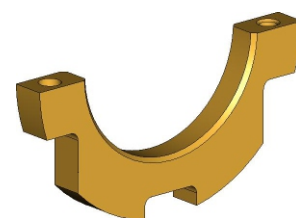
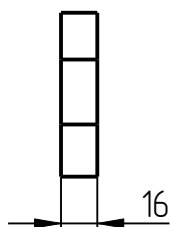
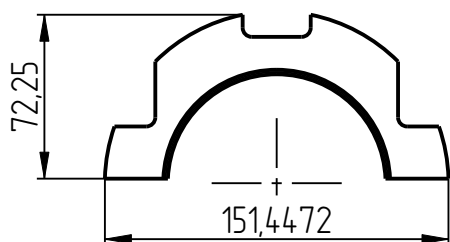

9. Гайка разрезная  
MT-401-001-008-01

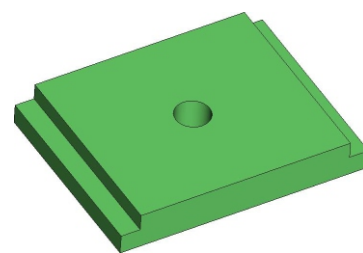
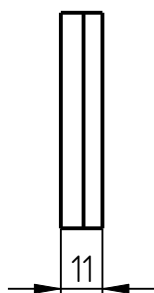
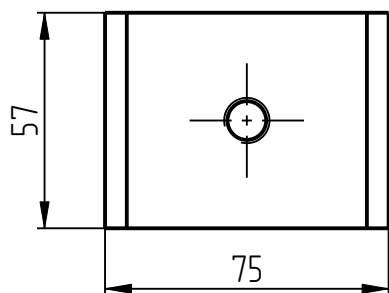

10. Прижим  
MT-401-001-009

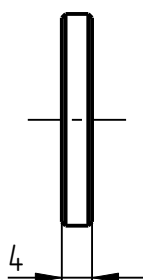
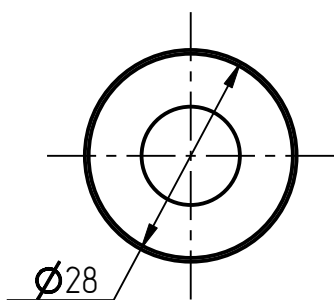

11. Шаўда  
MT-401-001-010

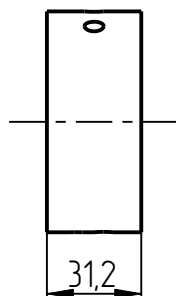
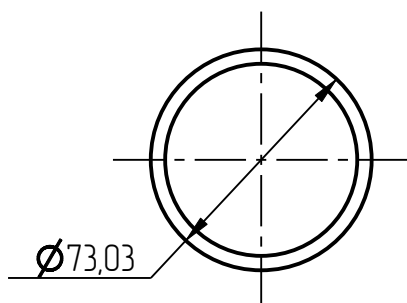

12. Кольцо  
MT-401-001-011

401

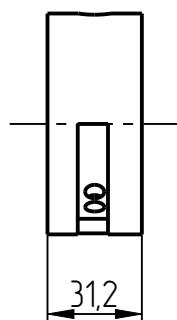
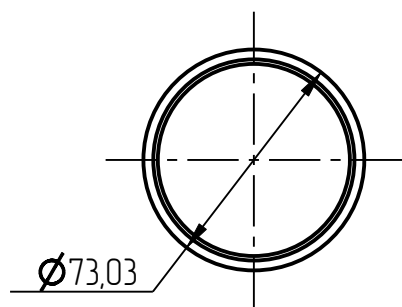

13. Кольцо  
MT-401-001-012